

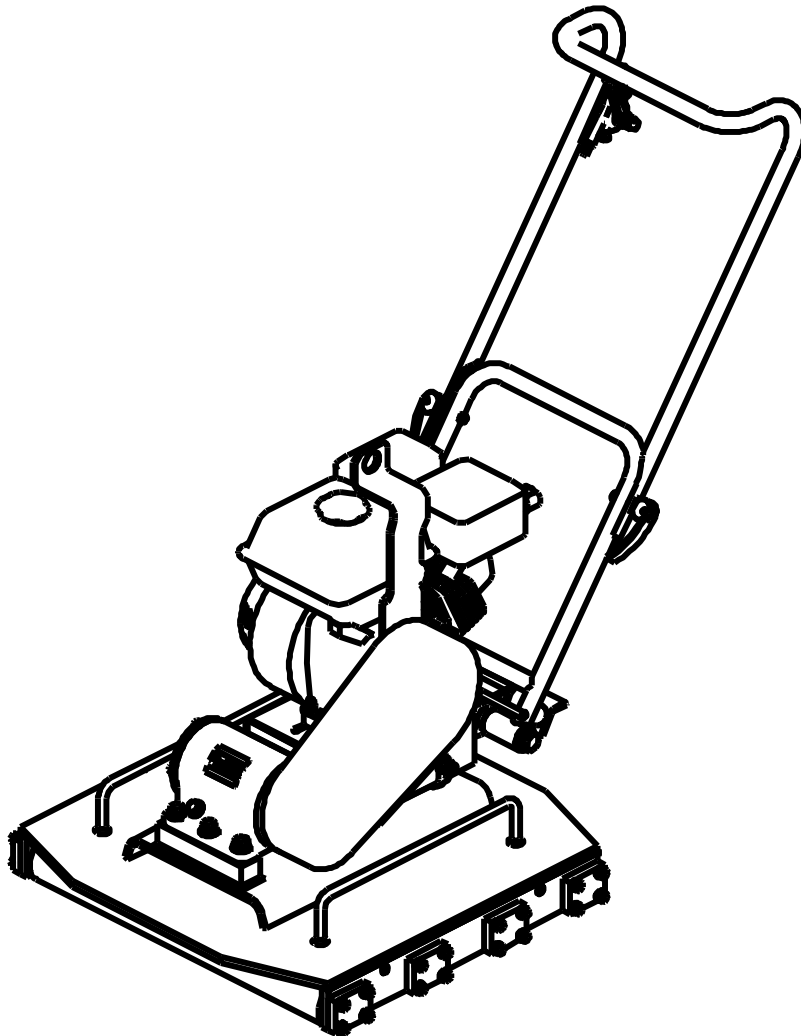

PCPT90P



Operator's Manual

Pavement Compactor

EC DECLARATION OF CONFORMITY / DECLARATION CE DE CONFORMITE / DECLARACIÓN DE CONFORMIDAD CE / DECLARAÇÃO CE DE CONFORMIDADE

GB/US

We, **Uni-corp Singapore, 20 Ang Mo Kio Industrial Park 2A, #03-02/03 AMK Techlink Singapore 567761**, hereby certify that if the product described within this certificate is bought from an authorised Hoppt dealer within the EEA, it conforms to the following directives: Machinery Directive 2006/42/EC, Electromagnetic Compatibility Directive 2004/108/EC (as amended by 92/31/EEC & 93/68 EEC). The physical agent (vibration) conforms with the directive 2002/44/EC. The low voltage directive 2006/95/EC, BS EN ISO 12100-1/2 Safety of machinery and associated harmonised standards, where applicable. Noise emissions conform to directive 2005/88/EC Annex VI), for machines under article 12 the notified body is **TÜV Rheinland Product Safety GmbH - Am Grauen Stein - D-51105 Köln, Germany**.

F

Nous soussignons, **Uni-corp Singapore, 20 Ang Mo Kio Industrial Park 2A, #03-02/03 AMK Techlink Singapore 567761**, certifions que si le produit décrit dans ce certificat est acheté chez un distributeur de la marque déposée "Hoppt" au sein de la EEA, celui-ci est conforme aux norms CEE ci-après: Norme de la machine 2006/42/CE, Norme compatible pour l'électromagnétisme 2004/108/CE (modifié par 92/31/CEE et 93/68/CEE). Le nombre de vibrations est en accord avec la directive 2002/44/CE. Caractéristiques basse tension 2006/95/CEE, BS EN ISO 12100-1/2, Norme de sécurité des machines et des critères associés et configurés, si applicable. Les émissions de bruit sont conformes à la directive 2005/88/CE Annexe VI pour machines, article 12. L'objet mentionné est **TÜV Rheinland Product Safety GmbH - Am Grauen Stein - D-51105 Köln, Allemagne**.

E

La Sociedad, **Uni-corp Singapore, 20 Ang Mo Kio Industrial Park 2A, #03-02/03 AMK Techlink Singapore 567761**, por el presente documento certifica que si el producto descrito en este certificado es comprado a un distribuidor autorizado de Hoppt en la EEA, este es conforme a las siguientes directivas: 2006/42/CE de la CEE, Directiva 2004/108/CEE sobre Compatibilidad Electromagnética (según enmiendas 92/31/CEE y 93/68 CEE). El numero de vibraciones esta de acuerdo con la Directiva 2002/44/CE. Directiva sobre Bajo Voltaje 2006/95/CEE, BS EN ISO 12100-1/2 de Seguridad de Maquinaria y Niveles armonizados estándares asociados donde sean aplicables. Emisión de Ruidos conforme a la Directiva 2005/88/CE Anexo VI para máquinas bajo artículo 12 la mencionada unidad está **TÜV Rheinland Product Safety GmbH - Am Grauen Stein - D-51105 Köln, Germany**.

P

O signatário, **Uni-corp Singapore, 20 Ang Mo Kio Industrial Park 2A, #03-02/03 AMK Techlink Singapore 567761**, pelo presente, declara que se o produto descrito neste certificado foi adquirido a um distribuidor autorizado do Hoppt em qualquer país da EEA, está em conformidade com o estabelecido nas seguintes directivas comunitárias: 2006/42/CE, Directiva de Compatibilidade Electromagnética 2004/108/CEE (conforme corrigido pelas 92/31/EEC & 93/68 EEC). O numero de vibrações está de acordo com a directiva 2002/44/CE LB. A directiva de baixa voltagem 2006/95/CEE, BS EN ISO 12100-1/2 Segurança da maquinaria e às normas harmonizadas afins se aplicáveis. As emissões de ruido respeitam e estão dentro das directivas para máquinas 2005/88/CE Anexo VI, artigo 12, sendo o organismo notificado **TÜV Rheinland Product Safety GmbH - Am Grauen Stein - D-51105 Köln, Germany**.

PRODUCT TYPE.....	TYPE DE PRODUIT....	TIPO DE PRODUCTO..	TIPO DE PRODUCTO..
MODEL.....	MODELE.....	MODELO.....	MODELO.....
SERIAL No.....	Nº DE SERIE.....	Nº DE SERIE.....	Nº DE SÉRIE.....
DATE OF MANUFACTURE.....	DATE DE FABRICATION.....	FECHA DE FABRICACIÓN.....	DATA DE FABRIC.....
WEIGHT.....	POIDS.....	PESO.....	PESO.....



Signed by:

Quality Manager - On behalf of Uni-corp Singapore PTE Ltd

Anita Tan

Foreword

This manual has been written to help you operate the Hoppt Pavement Compactor safely. It is intended primarily for dealers and operators of Hoppt Pavement Compactors. It is recommended that you keep this manual or a copy of it with the machine so that it is readily available for reference.

Before you operate or carry out any maintenance on this machine YOU MUST READ and UNDERSTAND this manual.

Should you have ANY QUESTIONS about the safe use or maintenance of this machine after reading this manual, ASK YOUR SUPERVISOR or CONTACT:

Uni-corp Singapore on +65 6756 7688

Hoppt reserves the right to change machine specification without prior notice or obligation.

Directions with regard notations

Text in this manual to which special attention must be paid are shown in the following way:



CAUTION

This CAUTION sign indicates a potential hazard, which if ignored, could result in injuries to the operator and/or those close by, as well as damaging the machine.



WARNING

This WARNING sign indicates a potential hazard, which if ignored could result in the DEATH of the operator and/or those close by.

Contents

Foreword	2
Safety Information	3-5
Machine Description.....	5
Pre-Start Checks.....	6
Start And Stop Procedure	6
Operation.....	7
Service and Maintenance.....	7-12
Transportation And Storage	12
Trouble Shooting.....	13
Technical Data	13
Warranty.....	14

Safety Information

For your own personal protection and for the safety of those around you, please read and ensure you fully understand the following safety information. It is the responsibility of the operator to ensure that he/she fully understands how to operate this equipment safely. If you are unsure about the safe and correct use of the Pavement Compactor, consult your supervisor or Hoppt.



CAUTION

Improper maintenance can be hazardous. Read and understand this section before you perform any maintenance, service or repairs.

General Safety

- The owner of this machine must observe, and also train the user of the machine to observe, the effective labour protection laws in the country of application.
- Use suitable lifting equipment to lift the machine.
- This machine is to be used for its intended application only.
- This machine must only be operated by well-trained personnel.
- Personal Protective Equipment (PPE) must be worn by the operator whenever the equipment is being used.
- The machine must be operated on ground where stability is guaranteed. When working near the rim of excavated trenches, keep a sensible distance from the edge so that there is no danger of the machine falling down or the trench collapsing.
- Cordon off the work area and keep members of the public and unauthorised personnel at a safe distance.
- Make sure you know how to safely switch this machine OFF before you switch it ON in case you run into any difficulties.
- Always switch OFF the engine before servicing it.
- During use, the engine becomes very hot. Always allow the engine to cool down before touching it.
- Never leave the engine running and unattended.
- Never remove or tamper with any fitted guards; they are there for your own protection. If they are damaged or missing, DO NOT USE THE MACHINE until the guard has been replaced or repaired.
- Always switch OFF the engine before transporting it, moving it around site or servicing it.
- Do not operate the machine when you are ill, feeling tired or when under the influence of alcohol or drugs.
- If the surface to be compacted is on a slope, take great care when controlling the Pavement Compactor's direction of travel. Always work up and down a slope; not across.
- This machine is designed to eliminate the possible risks arising from the use of it. However, risks DO reside, and these residual risks are not clearly recognisable and may cause personal injury or property damage, and possibly death. If such unpredictable and unrecognisable risks become

apparent, the machine must be stopped immediately, and operator or his supervisor must take appropriate measure to eliminate such risks. It is sometimes necessary that the manufacturer must be informed of such event for future counter measuring.

Fuel Safety



WARNING

Fuel is flammable. It may cause injury and property damage. Shut down the engine, extinguish all open flames and do not smoke while filling the fuel tank. Always wipe up any spilled fuel.

- Before re-fuelling, switch off the engine and allow it to cool.
- When re-fuelling, use a proper funnel, and avoid spilling over the engine.
- When re-fuelling, DO NOT smoke or allow naked flames in the area.
- Spilt fuel must be made safe immediately by using sand. If fuel is spilt on your clothes, change them.
- Store fuel in an approved, purpose made container away from heat and sources of ignition.

Health & Safety

Vibration

Some vibration from the compacting operation is transmitted through the handle to the operator's hands. Ensure operator rotation and do not exceed the maximum recommended usage times.

Dust

The compaction process can produce dust, which may be hazardous to your health. Always wear a mask that is suited to the type of dust being produced.

Fuel

Do not ingest fuel or inhale fuel vapors and avoid contact with your skin. Wash fuel splashes immediately. If you get fuel in your eyes, irrigate with copious amounts of water and seek medical attention as soon as possible.

Exhaust Fumes



WARNING

The exhaust fumes produced by this machine are highly toxic and can kill!

Do not operate the Pavement Compactor indoors or in confined spaces. Make sure the work area is adequately ventilated.

PPE (Personal Protective Equipment)

Suitable PPE must be worn when using this equipment i.e. safety goggles, gloves, ear defenders, dust mask and steel toe-capped footwear (with anti-slip soles for added protection). Wear clothing suitable for the work you are doing. Always protect skin from contact with concrete.

Machine Description

PCPT90P

1. Throttle
2. Operating Handle
3. Handle Adjuster
4. Belt Guard
5. Lifting Handle
6. Bearing Cover
7. Roller
8. Exciter Housing
9. Engine
10. Lifting Hook

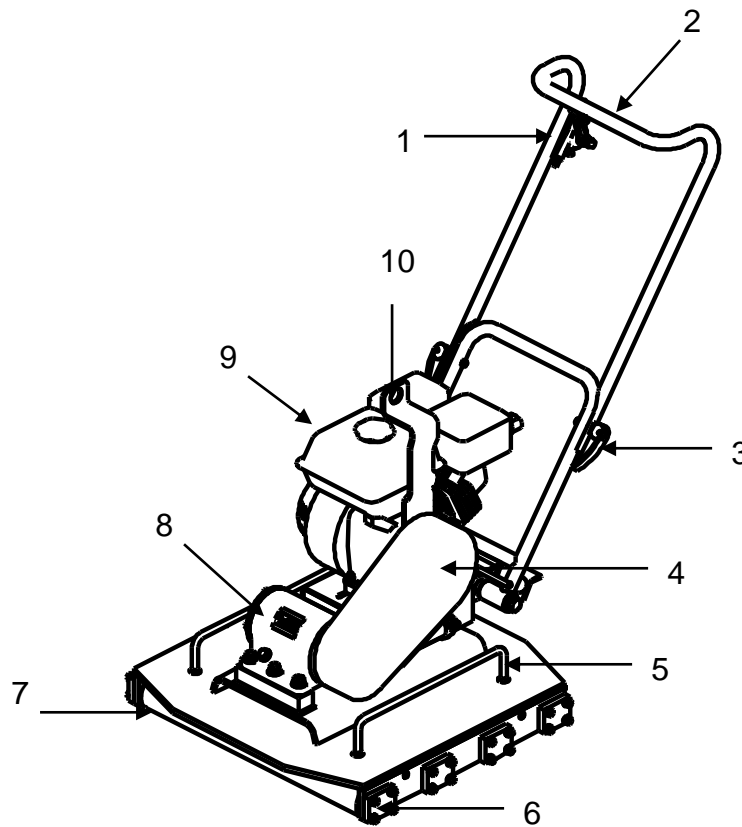

Pre-start Checks

The following pre-start checks must be performed before the start of each work session or after every four hours of use, whichever is first. Please refer to the Service and Maintenance section for detailed guidance. If any fault is discovered, the Pavement Compactor must not be used until the fault is rectified.

1. Thoroughly inspect the machine for signs of damage, Make sure all guards are in place and secured.
2. Check hoses, filler openings, drain plugs and other areas for signs of leakage. Fix any leaks before operating.
3. Check the engine oil level and top up as necessary. Use proper engine oil with the proper viscosity (SAE 10W-30 is recommended).
4. Check the engine fuel level and top us as necessary. Use clean fuel. The use of contaminated fuel may damage the fuel system.
5. Check the air filter is clean. Excessive dirt/dust accumulation within the filter element will cause erratic engine operation. Clean the air filter element when it is contaminated (refer to the Service and Maintenance section).
6. Check for fuel and oil leaks.

Start/Stop Procedure

Before starting the engine, make sure that the Safety Switch is in the ON position and the Throttle Lever is set to the idle position.

1. Take the Pavement Compactor to where it is required. Use suitable lifting equipment to position the Pavement Compactor where it is necessary. Make sure the lifting equipment has a WLL (Working Load Limit) suitable for the Pavement Compactor weight. Attach suitable slings or chains only to the lifting point.
2. Never leave the engine running during transporting, even if it is for a short period of time.
3. Having carried out the checks listed in the 'pre-start' section, you may start the engine. Hoppt Pavement Compactors are fitted with a centrifugal clutch which allows the engine to run at idle speed without driving the Pavement Compactor. Centrifugal clutch will be engaged as the speed of engine is increased. For correct operation, the engine speed should be set to maximum.

Before Starting Gasoline Engine

4. Check the oil in the engine crankcase. Be sure to maintain the proper level per the engine manufacturer specifications. If the oil is dirty and in need of changing, follow the Engine User Manual instructions.
5. Check the fuel supply. Refer to Engine User Manual.

Operation

1. Run the engine at full throttle and allow the Pavement Compactor to pull itself along at its normal speed.
2. When operating on an incline it may be necessary to assist the Pavement Compactor by pushing it forward slightly.
3. When operating downhill hold the Pavement Compactor back slightly, if it begins to pick up speed.
4. Depending on the material being compacted, 3 or 4 passes are recommended to achieve the best compaction.

Service and Maintenance

The Hoppt Pavement Compactors are designed to give many years of trouble free operation. It is, however, important that the simple regular maintenance listed in this section is carried out. It is recommended that an approved Hoppt dealer carry out all major maintenance and repairs. Always use genuine Hoppt replacement parts, the use of spurious parts may void your warranty. Before any maintenance is carried out on the machine, switch off the engine and disconnect the HT lead from the spark plug. Always set the machine on level ground to ensure any fluid levels will be correctly read. Only use recommended oils.

Routine Maintenance	Daily before starting	After first 20 hours	Every 2 weeks or 50 hours	Every month or 100 hours	Every year or 300 hours
Check Fuel Level	◆				
Check Engine Oil Level	◆				
Inspect Fuel Lines	◆				
Inspect Air Filter. Replace as needed.	◆				
Check and Tighten External Hardware	◆				
Check and Adjust Drive Belt		◆	◆		
Clean Air Cleaner Element			◆		
Check Exciter Oil Level			◆		
Change Engine Oil		◆		◆	
Check and Clean Spark Plug				◆	
Clean Sediment Cup				◆	
Check and Adjust Valve Clearance					◆
Change Exciter Oil					◆

Air Cleaner

The engine is equipped with a dual element air cleaner. Air cleaner must be serviced regularly to prevent carburetor failure.



Never run the engine without the air cleaner. Severe engine damage will occur.

To Service (Figure 1):

- i. Remove air cleaner cover (a). Remove both elements and inspect them for holes or tears. Replace damaged elements.
- ii. Wash foam element (b) in solution of mild detergent and warm water. Rinse thoroughly in clean water. Allow element to dry thoroughly. Soak element in clean engine oil and squeeze out excess oil.
- iii. Tap paper element (c) lightly to remove excess dirt. Replace paper element if it appears heavily soiled.

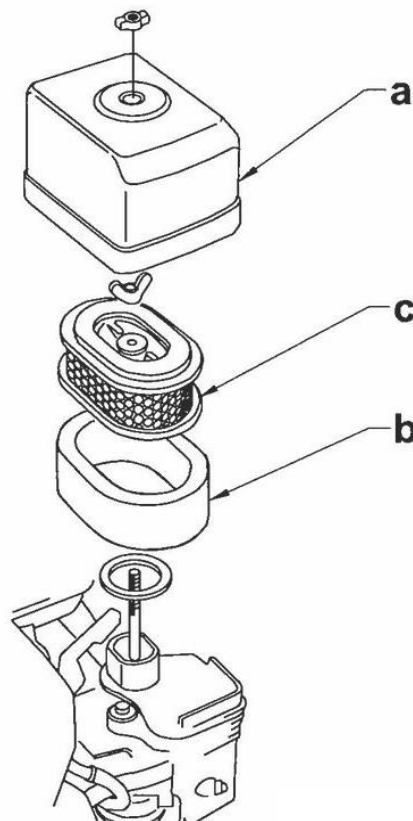

Figure 1

Engine Oil (Figure 2)

1. Drain oil while engine is still warm.
2. Remove the oil fill plug (a) and drain plug (b) to drain oil.
Note: In the interests of environmental protection, place a plastic sheet and a container under the machine to collect any liquid which drains off. Dispose of this liquid in accordance with environmental protection legislation.
3. Install drain plug.
4. Fill the engine crankcase with recommended oil up to the level of the plug opening (c). See engine user manual for oil type and quantity.
5. Refit the oil filler plug.

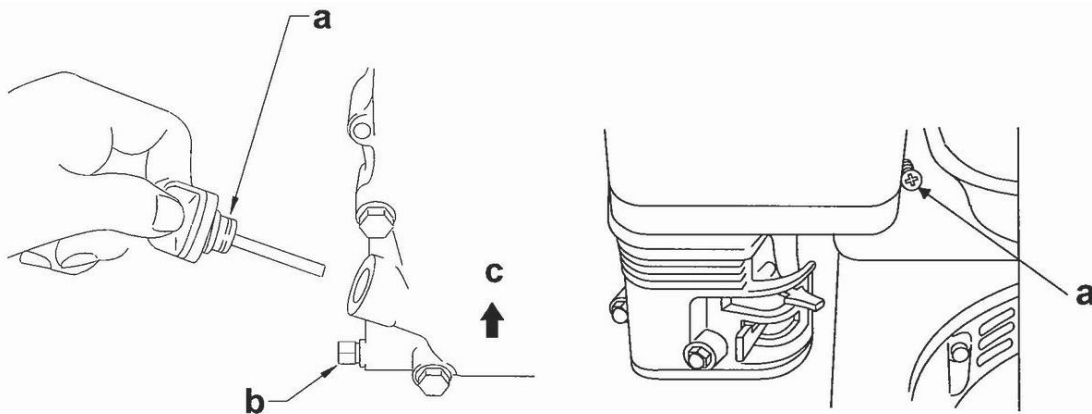

Figure 2

Carburetor Adjustment (Figure 3)

1. Start the engine and allow it to warm up to operating temperature.
2. Set the pilot screw (a) 2 turns out. See note.
3. With the engine idling, turn the pilot screw (a) in or out to the setting that produces the highest rpm.
4. After the pilot screw is adjusted, turn the throttle stop screw (b) to obtain the standard idle speed.

Note: On some engines the pilot screw is fitted with a limiter cap (c) to prevent excessive enrichment of the air-fuel mixture in order to comply with emissions regulations. The mixture is set at the factory and no adjustments should be necessary. Do not attempt to remove the limiter cap. The limiter cap cannot be removed without breaking pilot screw.

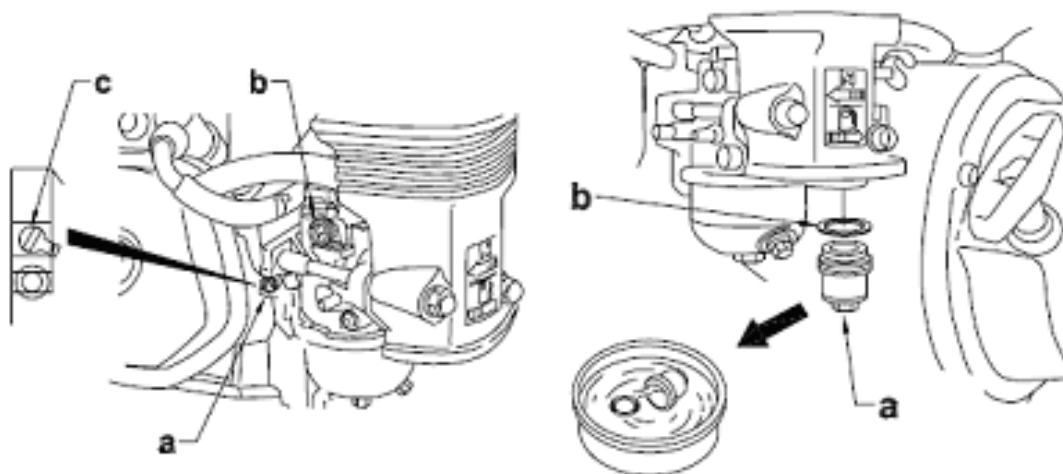

Figure 3

Drive Belt

On new machines or after installing a new belt, check the belt tension after first 20 hours of operation. Check and adjust the belt every 50 hours thereafter.

To adjust the belt:

1. Loosen the 2 screws on the belt guard (4 screws on box type), then remove the belt guard, keeping the screw assemblies captured on the belt guard.
2. Loosen the 4 nuts which hold the engine to the engine mounting plate and the belt screw.
3. Slide the engine backward (towards the handle) to tighten the belt, forward to loosen the belt.
4. Adjust the belt so that it deflects 10 – 15mm when pressed midway between the belt pulleys.
5. Then tighten the belt screw which prevents the engine from sliding forward.
6. Make sure the clutch pulley and the exciter pulley are in alignment. Place a straight edge against the exciter pulley and move the engine so that the two pulleys are parallel.
7. Retighten all nuts and screws to secure.

Exciter Lubrication

The bearings in the exciter assembly are splash lubricated and rotate at very high speed. It is crucial to maintain the exciter oil at the correct level and change it regularly.

Check exciter oil level every 50 hours of operation. (Use SAE-30W)

To check oil level:

1. Place plate on a flat level surface.
2. Remove the Oil Filler Plug.

Cleaning the Pavement Compactor

Clean rollers after use to remove dirt, stones, and mud caught under the engine console. If compactor is being used in a dusty area, check engine cylinder cooling fins for heavy dirt accumulation. Keep engine cylinder fins clean to prevent engine from overheating. You may use an air gun to blow away excessive dirt.

Transportation and Storage

For long-term storage, empty the fuel in the carburetor by running the engine with the fuel tap being closed.

The chemical composition of the fuel will deteriorate after prolonged storage. When the machine needs to be stored for a long time, remove all the fuel from the fuel tank and the water from the water tank. Also remove the fuel from the float chamber of the carburetor by draining the fuel out from the drain plug.

Clean excessive dirt accumulated on the Pavement Compactor. Cover the machine and store it in a dry place.



CAUTION

Extreme care must be taken when loading or unloading this machine.

Always use the lifting hook for hoisting purposes. Use proper hoisting equipment and techniques.

Be certain the area surrounding the machine is clear of personnel before hoisting. Always hoist the machine high enough to transport.

Trouble Shooting

Problems	Possible Causes	Countermeasures
Engine will not start.	<ul style="list-style-type: none"> a. No fuel getting to engine. b. Engine switched off. c. Spark plug fouled. d. Engine cold. e. Engine flooded. 	<ul style="list-style-type: none"> a. Open fuel tap. Fill fuel tank. b. Switch engine on. c. Clean, check and reset plug gap. d. Close choke. e. Open choke, fully open throttle, pull recoil starter until engine fires.
Unit will not vibrate.	<ul style="list-style-type: none"> a. Engine speed too slow. b. Drive belt tension loose. c. Air Filter Blocked. d. Drive Failure. e. Exciter Failure. 	<ul style="list-style-type: none"> a. Set throttle speed to fast. b. Adjust belt tension. c. Clean or change air filter. d. Contact agent or Hoppt. e. Contact agent or Hoppt.

Technical Data

MODEL	PCPT 90P
Dimension (LxWxH) - mm (in)	665 x 670 x 1,200 (27.6 x 26.9 x 48.3)
Operating Weight - kg (lbs)	123 (271)
Plate Size (LxW) - mm (in)	655 x 620 (27.6 X 24.9)
Centrifugal Force - kg (lbs)	1,050 (2,315)
Compacted Area - m ² /h (ft ² /h)	600-700 (6,458 - 7,534)
Engine	HONDA GX160 / EY20-3C
Engine Type	4-STROKE GASOLINE
Max. Power Output - Hp (kW)	GX160@5.5(4) / EY20-3C@5.0 (3.7)
Max. Engine Speed - rpm	GX160@3,600 / EY20-3C@4,000

Warranty

Your new Pavement Compactor is warranted to the original purchaser for a period of one-year (12 months) from the original date of purchase. The Hoppt warranty covers defects in design, materials and workmanship.

The following are not covered under the Hoppt warranty:

1. Damage caused by abuse, misuse, dropping or other similar damage caused by or as a result of failure to follow assembly, operation or user maintenance instructions.
2. Alterations, additions or repairs carried out by persons other than Hoppt or their recognised agents.
3. Transportation or shipment costs to and from Hoppt or their recognised agents, for repair or assessment against a warranty claim, on any machine.
4. Materials and/or labour costs to renew, repair or replace components due to fair wear and tear.
5. The engine, air filter and the engine spark plug.

Hoppt and/or their recognised agents, directors, employees or insurers will not be held liable for consequential or other damages, losses or expenses in connection with or by reason of or the inability to use the machine for any purpose.

Warranty Claims

All warranty claims should firstly be directed to the local dealer, either by telephone, by fax, by email, or in writing.

Liability

HOPPT declines any liability for possible damages to persons and/or things, which might arise from improper or wrong use of the machine or non-observance of the operating instructions in this manual.

USE ONLY GENUINE HOPPT PARTS AND ACCESSORIES!

For your own safety, the safety of others and the life of the machine.



Uni-corp (Singapore) PTE Ltd

20 Ang Mo Kio Industrial Park 2A,
#03-02/03 AMK Techlink Singapore 567761

 +65 6756 7688

 +65 6756 7088

 sales@uni-corp.com

 www.uni-corp.com

