



RAM60B/RAM70C



Operator's Manual

Gasoline Rammers

EC DECLARATION OF CONFORMITY

GB/US

We, **Uni-corp Europe, 33 Avenue Pierre Brossolette, 94048 Créteil Cedex, France**, hereby certify that if the product described within this certificate is bought from an authorised Paclite dealer within the EEA, it conforms to the following directives: Machinery Directive 2006/42/EC, Electromagnetic Compatibility Directive 2004/108/EC (as amended by 92/31/EEC & 93/68 EEC). The physical agent (vibration) conforms with the directive 2002/44/EC. The low voltage directive 2006/95/EC, BS EN ISO 12100-1/2 Safety of machinery and associated harmonised standards, where applicable. Noise emissions conform to directive 2005/88/EC Annex VI), for machines under article 12 the notified body is **TÜV Rheinland Product Safety GmbH - Am Grauen Stein - D-51105 Köln, Germany**.

F

Nous soussignons, **Uni-corp Europe, 33 Avenue Pierre Brossolette, 94048 Créteil Cedex, France**, certifions que si le produit décrit dans ce certificat est acheté chez un distributeur de la marque déposée "Paclite" au sein de la EEA, celui-ci est conforme aux norms CEE ci-après: Norme de la machine 2006/42/CE, Norme compatible pour l'électromagnétisme 2004/108/CE (modifiée par 92/31/CEE et 93/68/CEE). Le nombre de vibrations est en accord avec la directive 2002/44/CE. Caractéristiques basse tension 2006/95/CEE, BS EN ISO 12100-1/2, Norme de sécurité des machines et des critères associés et configurés, si applicable. Les émissions de bruit sont conformes à la directive 2005/88/CE Annexe VI pour machines, article 12. L'objet mentionné est **TÜV Rheinland Product Safety GmbH - Am Grauen Stein - D-51105 Köln, Allemagne**.

E

La Sociedad, **Uni-corp Europe, 33 Avenue Pierre Brossolette, 94048 Créteil Cedex, France**, por el presente documento certifica que si el producto descrito en este certificado es comprado a un distribuidor autorizado de Paclite en la EEA, este es conforme a las siguientes directivas: 2006/42/CE de la CEE, Directiva 2004/108/CEE sobre Compatibilidad Electromagnética (según enmiendas 92/31/CEE y 93/68 CEE). El numero de vibraciones esta de acuerdo con la Directiva 2002/44/CE. Directiva sobre Bajo Voltaje 2006/95/CEE, BS EN ISO 12100-1/2 de Seguridad de Maquinaria y Niveles armonizados estándares asociados donde sean aplicables. Emisión de Ruidos conforme a la Directiva 2005/88/CE Anexo VI para máquinas bajo artículo 12 la mencionada unidad está **TÜV Rheinland Product Safety GmbH - Am Grauen Stein - D-51105 Köln, Germany**.

P

O signatário, **Uni-corp Europe, 33 Avenue Pierre Brossolette, 94048 Créteil Cedex, France**, pelo presente, declara que se o produto descrito neste certificado foi adquirido a um distribuidor autorizado do Paclite em qualquer país da EEA, está em conformidade com o estabelecido nas seguintes directivas comunitárias: 2006/42/CE, Directiva de Compatibilidade Electromagnética 2004/108/CEE (conforme corrigido pelas 92/31/EEC & 93/68 EEC). O numero de vibrações está de acordo com a directiva 2002/44/CE LB. A directiva de baixa voltagem 2006/95/CEE, BS EN ISO 12100-1/2 Segurança da maquinaria e às normas harmonizadas afins se aplicáveis. As emissões de ruído respeitam e estão dentro das directivas para máquinas 2005/88/CE Anexo VI, artigo 12, sendo o organismo notificado **TÜV Rheinland Product Safety GmbH - Am Grauen Stein - D-51105 Köln, Germany**.

RUS

Мы, компания **Uni-corp Europe, 33 Avenue Pierre Brossolette, 94048 Créteil Cedex, France**, настоящим подтверждаем, что если упомянутая в настоящей декларации продукция приобретена у уполномоченного представителя Paclite в Европейской экономической зоне, она отвечает требованиям перечисленных ниже директив: Директива по машиностроению 2006/42/ЕС, Директива о электромагнитной совместимости 2004/108/ЕС (с добавлениями 92/31/ЕЕС и 93/68 ЕЕС). Рабочее воздействие (вибрация) соответствует требованиям Директивы 2002/44/ЕС. Директива о низковольтном оборудовании 2006/95/ЕС, BS EN ISO 12100-1/2 Гармонизированные стандарты по безопасности машин и связанные с ними другие гармонизированные стандарты (где применимо). Шумовое воздействие в соответствии с директивой 2005/88/ЕС Приложение VI). Для машин, соответствующих требованиям статьи 12, уполномоченным органом является **TÜV Rheinland Product Safety GmbH – Am Grauen Stein – D- 51105 Köln, Germany**.

RO

Noi, **Uni-corp Europe, 33 Avenue Pierre Brossolette, 94048 Créteil Cedex, France**, prin prezenta certificăm că produsul descris în acest certificat și cumpărat de la un distribuitor autorizat Paclite din EEA, este realizat în conformitate cu următoarele directive: Directiva pentru echipamente 2006/42/EC, Directiva privind compatibilitatea electromagnetica 2004/108/EC (modificată conform 92/31/EEC & 93/68 EEC). Agentul fizic (vibrația) este conform cu directiva 2002/44/EC. Directiva pentru curenți mici 2006/95/EC, BS EN ISO 12100-1/2 Siguranța echipamentelor și asociată standardelor armonizate, unde este aplicabil. Emisiile de zgomot conform directivei 2005/88/EC Annex VI), pentru echipamente la articolul 12 certificată de **TÜV Rheinland Product Safety GmbH - Am Grauen Stein - D-51105 Köln, Germania**.

PRODUCT TYPE.....	TYPE DE PRODUIT.....	TIPO DE PRODUCTO..	TIPO DE PRODUCTO..	ТИП ИЗДЕЛИЯ.....	TIP PRODUS.....
MODEL.....	MODELE.....	MODELO.....	MODELO.....	МОДЕЛЬ.....	MODEL.....
SERIAL No.....	N° DE SERIE.....	N° DE SERIE.....	N° DE SÉRIE.....	СЕРИЙНЫЙ №.....	SERIE
DATE OF	DATE DE	FECHA DE	DATA DE	ДАТА	DATA
MANUFACTURE.....	FABRICATION.....	FABRICACIÓN.....	FABRICO.....	ИЗГОТОВЛЕНИЯ...	DE PRODUCTIE.....
WEIGHT.....	POIDS.....	PESO.....	PESO.....	МАССА.....	GREUTATE.....



Signed by:
Signature:

Anita Tan

Quality Manager - On behalf of Uni-corp

Foreword

This manual has been written to help you operate the rammer safely. It is intended primarily for dealers and operators. It is recommended that you keep this manual or a copy of it with the machine so that it is readily available for reference.

Before you operate or carry out any maintenance on this machine YOU MUST READ and UNDERSTAND this manual.

Should you have ANY QUESTIONS about the safe use or maintenance of this machine after reading this manual, ASK YOUR SUPERVISOR or CONTACT:

Uni-corp Singapore on +65 6756 7688

We reserve the right to change machine specification without prior notice or obligation.

Directions with regard notations

Text in this manual to which special attention must be paid are shown in the following way:



CAUTION

This CAUTION sign indicates a potential hazard, which if ignored, could result in injuries to the operator and/or those close by, as well as damaging the machine.



WARNING

This WARNING sign indicates a potential hazard, which if ignored could result in the DEATH of the operator and/or those close by.

Contents

Foreword	2
Safety Information	3-5
Environment	5
Machine Description.....	6
Pre-Start Checks	7
Start And Stop Procedure	7-8
Operation.....	9
Service and Maintenance.....	9-10
Transportation And Storage	10-11
Trouble Shooting.....	12
Technical Data	12
Warranty.....	13

Safety Information

For your own personal protection and for the safety of those around you, please read and ensure you fully understand the following safety information. It is the responsibility of the operator to ensure that he/she fully understands how to operate this equipment safely.



Improper maintenance can be hazardous. Read and understand this section before you perform any maintenance, service or repairs.

If you are unsure about the safe and correct use of the Rammer, consult your supervisor or Hoppt

General Safety

- This machine is heavy and must not be lifted single-handedly; either get help or use suitable lifting equipment.
- This machine is to be used for its intended application only.
- This machine must only be operated by well-trained personnel.
- The owner of this machine must observe, and train the user to observe, the effective laws of labour protection in the country of application.
- Personal Protective Equipment (PPE) must be worn by the operator whenever the equipment is being used.
- Cordon off the work area and keep members of the public and unauthorised personnel at a safe distance.
- This machine must be operated on ground where stability is guaranteed. When working near the rim of excavated trenches, use the machine properly so that the machine may not fall down or collapse the excavation.
- Make sure you know how to safely switch this machine OFF before you switch it ON in case you run into any difficulties.
- Always switch OFF the engine before servicing it.
- During use, the engine becomes very hot. Always allow the engine to cool down before touching it.
- Never leave the engine running and unattended.
- Never remove or tamper with any fitted guards; they are there for your own protection. If they are damaged or missing, DO NOT USE THE MACHINE until the guard has been replaced or repaired.
- Always switch OFF the engine before transporting it, moving it around site or servicing it.
- Do not operate the machine when you are ill, feeling tired or when under the influence of alcohol or drugs.
- This machine is designed to eliminate the possible risks arising from the use of it. However, risks DO reside, and these residual risks are not clearly recognisable and may cause personal injury or

property damage, and possibly death. If such unpredictable and unrecognisable risks become apparent, the machine must be stopped immediately, and operator or his supervisor must take appropriate measure to eliminate such risks. It is sometimes necessary that the manufacturer must be informed of such event for future counter measuring.

Fuel Safety



WARNING

Fuel is flammable. It may cause injury and property damage. Shut down the engine, extinguish all open flames and do not smoke while filling the fuel tank. Always wipe up any spilled fuel.

- Before re-fuelling, switch off the engine and allow it to cool.
- When re-fuelling, use a proper funnel, and avoid spilling over the engine.
- When re-fuelling, DO NOT smoke or allow naked flames in the area.
- Spilt fuel must be made safe immediately by using sand. If fuel is spilt on your clothes, change them.
- Store fuel in an approved, purpose made container away from heat and sources of ignition.

Health & Safety

Vibration

Some vibration from the compacting operation is transmitted through the handle to the operator's hands. Ensure operator rotation and do not exceed the maximum recommended usage times.

Dust

The compaction process can produce dust, which may be hazardous to your health. Always wear a mask that is suited to the type of dust being produced.

Fuel

Do not ingest fuel or inhale fuel vapors and avoid contact with your skin. Wash fuel splashes immediately. If you get fuel in your eyes, irrigate with copious amounts of water and seek medical attention as soon as possible.

Exhaust Fumes



WARNING

The exhaust fumes produced by this machine are highly toxic and can kill!

Do not operate the rammer indoors or in confined spaces. Make sure the work area is adequately ventilated.

PPE (Personal Protective Equipment)

Suitable PPE must be worn when using this equipment i.e. safety goggles, gloves, ear defenders, dust mask and steel toe-capped footwear (with anti-slip soles for added protection). Wear clothing suitable for the work you are doing. Always protect skin from contact with concrete.

Environment

In order to protect the environment please recycle any discarded apparatus or accessories. The table beside provides you with a list of the machine's components and their respective materials. Take the discarded apparatus to the relevant recycling facilities.



Component	Material
Handle	Steel
Ramming Shoe	Plywood and Steel
Rubber Isolators	Rubber and Steel
Bellow	Urethane
Crankcase	Aluminium
Crankcase Cover	Aluminium
Gears	Steel
Engine	Steel and Aluminium
Various Parts	Steel and Aluminium

Machine Description

RAM60B/RAM70C

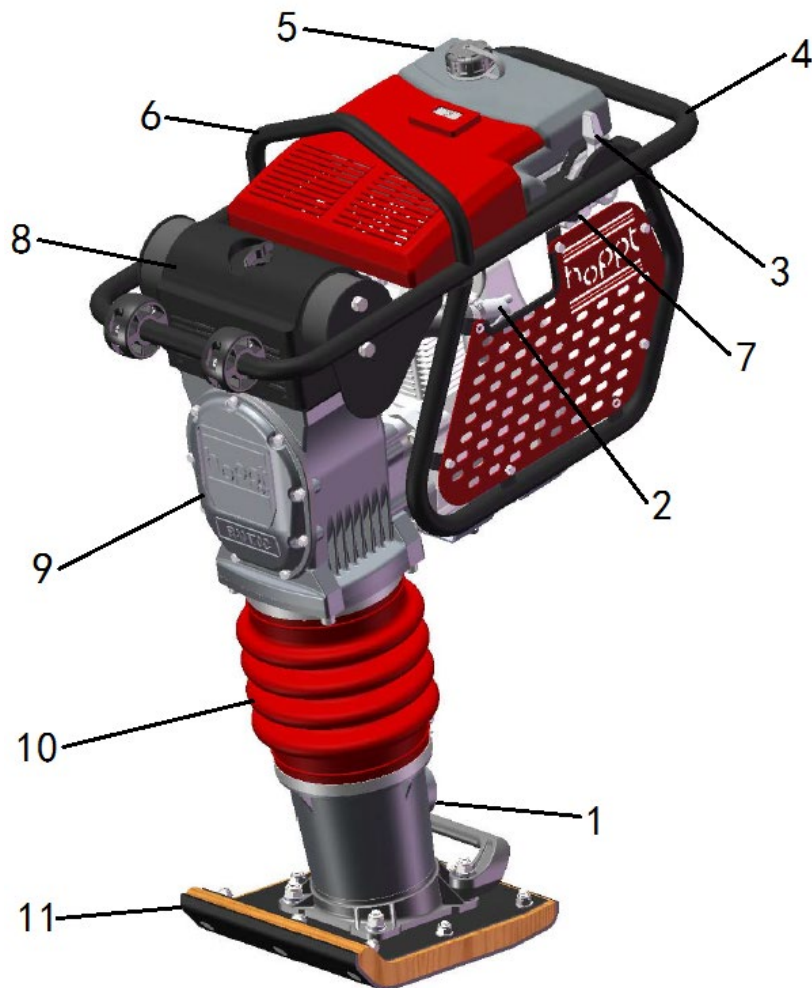

1. Oil Plug/Sight Glass
2. Engine
3. Throttle Lever
4. Operating Handle
5. Fuel Tank
6. Lifting Point
7. Fuel ON/OFF Lever
8. Primary Air Cleaner
9. Crankcase
10. Bellow
11. Ramming Shoe/Foot

Intended Use

This machine is intended for base preparation, driveways, foundations, curbs, and footings. It can also be used for repair work on streets, highways and/or pavements/sidewalks.

Pre-Start Checks

Inspection prior to start-up

The following inspection must be performed before the start of each work session or after every four hours of use, whichever is first. Please consult the Service and Maintenance section for detailed guidance. If any fault is discovered, the machine must not be used until the fault is rectified.

1. Thoroughly inspect the machine for signs of damage.
2. Check hoses, filler openings, drain plugs and any other areas for signs of leakage. Fix any leaks before operating.
3. Check the engine oil level and top up as necessary.

3.1 Place the machine on a level surface and check the oil in the engine.

3.2 Use proper engine oil with the proper viscosity (SAE 10W-30 is recommended).

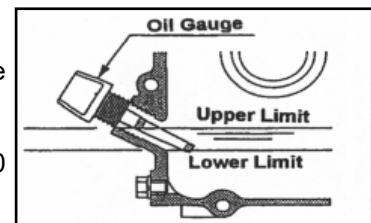

4. Check the engine fuel level and top up if required. Use clean fuel. Use of contaminated fuel may damage the fuel system.



CAUTION

This machine uses unleaded petrol/gasoline!!

5. Check the air filter is clean. Excessive dirt/dust accumulation within the filter element will cause erratic engine operation. Clean the air filter if it is contaminated (see Service and Maintenance section).

Start and Stop Procedure



CAUTION

Improper operation can be hazardous. Read and understand this section before you start the machine.

1. Open the fuel cock.
2. Set the engine switch to the ON position.
3. Set the speed control lever to the STARTING position (Halfway between HIGH and LOW position).
4. Move the choke lever to the CLOSED position.
5. Taking a firm hold of the Operating handle with one hand, grasp the recoil starter handle with the other, Pull the recoil starter handle until engine resistance is felt, then let starter return.
6. Taking care not to pull the starter rope fully out, pull the starter handle briskly.
7. Repeat until the engine fires.
8. Once the engine fires gradually set the choke lever to the OPEN position.
9. Let the engine run at idle for a few minutes to warm up.

10. After the engine has warmed up, the machine is ready for operation.
11. Move the throttle lever to the high speed 'H' position quickly to prevent damage from occurring to the clutch. The 'Full Throttle' position of this machine has been preset at the factory to achieve optimum machine performance.
12. With the engine running in the full throttle position, the machine will move forward and compact loose 'lifts'
13. In preparation for stopping the engine, move the throttle lever to the LOW position.
14. Allow the engine to idle for 1-3 minutes.
15. Move the throttle lever to the STOP position. Do not touch the HOT engine part at this time.
16. Pull the recoil starter slowly until you feel resistance. Then release your hand from the starter knob to set it back to its original position. This will prevent any air or humidity from entering into the cylinder.

Model	Engine	Maximum RPM	
		Optimum	Upper Limit
RAM60B	ROBIN ER12 HONDA GX100	3700~3800	4100
RAM70C	ROBIN ER12 HONDA GX100	3700~3800	4100

The Max rpm as shown above is the number of ignitions per minute. The number of ignitions per minute is different from the number of rotations of the engines Power Take-Off Shaft.



CAUTION

DO NOT alter this setting since irregular vibration or damage to the gear transmission mechanism can result, and both engine and machine warranties will be automatically voided.

Having carried out the check in the 'Pre-Start' section, you may now start the engine.

Operation

This machine is fitted with a centrifugal clutch. This allows the engine to run at idle without driving the power transmission gears. As the engine speed is increased, the clutch will engage and the engine will drive the power transmission gears.

- To avoid damage to the centrifugal clutch, move the throttle lever quickly from the L to H position. For correct operation, the engine speed should be set to maximum.
- Avoid operating the machine on a fully compacted, hard, or non-yielding surface. Otherwise, the power transmission gears will be damaged and the life of the machine will be greatly reduced.
- When working in a narrow trench, if the ramming shoe should get caught between the walls of the trenches, the rammer may miss-strike and can be severely damaged.
- Be sure that the rammer is steered only with the handle. It should only be pushed. The rammer must not be pressed into the materials being compacted. Excessive pressure on the operating handle will lead to the unsatisfactory compaction due to the fact that the jumping action is hindered.

Operation at High Altitude

For continuous High-Altitude operation above 1,000m (3,000FT), it will be necessary to change the engine main jet to a type that will allow for correct fueling of the engine. Otherwise, the unit will suffer from a lack of engine power and not work correctly. Please contact dealers for details.

Service and Maintenance

The Rammers are designed to give many years of trouble free operation. It is, however, important that the simple regular maintenance listed in this section is carried out. It is recommended that an approved dealer carry out all major maintenance and repairs. Always use genuine replacement parts, the use of spurious parts may void your warranty.

Before any maintenance is carried out on the machine, switch off the engine and disconnect the HT lead from the spark plug. Always set the machine on level ground to ensure any fluid levels will be correctly read. Only use recommended oils.

Servicing the Engine

Service the engine according to the engine manufacturer's specifications. Refer to the engine operation and maintenance manual.

Maintenance: Every 8 hours or daily

1. Check for loose bolts and nuts, retighten if necessary.
2. Check and clean the air filter element, re-lube the element in accordance with the engine manufacturer's recommendations. If operating conditions are unusually dusty and severe, filter element cleaning should be done more frequently.

3. Check oil level in crankcase of engine and replenish as necessary. Check the oil level in the ramming cylinder according to the following procedures:

- Make sure that the machine has not been run in the last 10 minutes.
- Set the machine on a level surface and remove the oil plug.
- The top surface of the oil must be seen just below the lower rim of the hole on the oil sight glass. Replenish as necessary.

NOTICE: Care should be taken not to overfill the rammer with oil. Overfilling will cause excessive load on the engine, which may result in poor or irregular vibration.

Maintenance: Every 50 hours or weekly

Check for loose bolts and nuts. Retighten if necessary.

Maintenance: Every 200 hours

Check the ramming cylinder oil. Do not overfill.

Fuel, Lubricant

Model	Fuel		Engine Crankcase			Ramming Cylinder	
	Type	Capacity	Type	Engine	Capacity	Type	Capacity
RAM60B	Unleaded Gasoline	3.8L	SAE 10W – 30, API, SG, SF/CC, CD	ROBIN ER12 HONDA GX100	0.30L	SAE 10W – 30, API, SG, SF/CC, CD	0.5L
RAM70C						0.8L	

Transportation and Storage

Lifting

Where it is necessary to use lifting equipment to position the rammer, check and confirm that the rubber isolators on the operation handle is not damaged or cracked. If they are cracked or damaged, replace the rubber isolators before attempting to lift the machine. Also make sure that the lifting equipment has a WLL (Working Load Limit) suitable for the rammer's weight (See specification chart on page 12 or the machine number plate). Attach suitable chains or slings ONLY to the lifting point on top of the rammer's operating handle.

- NEVER leave the engine running whilst transporting or moving the rammer, even if it is only a short distance.

On Site Transport

The rammer may be moved vertically by 2 people, or laid only on the Transport Rollers.

Road Transport

The rammer must be transported as far as possible standing up, strapped to the body side board of the truck, or strapped inside a lorry (panel truck). If not possible, it may be laid down (engine facing upwards, not on its sides) only on the Transport Rollers, in a stable position and strongly strapped down to guard against rolling or sliding.



CAUTION

Wait until the unit is completely cool before laying it down.

Long-term Storage

The chemical composition of the fuel will deteriorate after prolonged storage. When the machine needs to be stored for a long time, remove all the fuel from the fuel tank. You can achieve this by running the engine with the fuel tap being closed (see picture). Also remove the fuel from the drain plug.

Clean up oil and dust accumulation on rubber parts.

Clean the base plate and apply a light coating of oil to prevent rust formation.

Cover the machine and store in a dry place.

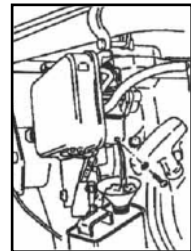

Trouble Shooting

Problems	Possible Causes	Countermeasures
Engine will not start	<ol style="list-style-type: none"> 1. No fuel. 2. Fuel tap has been closed. 3. Engine turned off. 4. Contaminated/damaged spark plug. 5. Faulty carburetor 	<ol style="list-style-type: none"> 1. Fill fuel tank. 2. Open fuel tap. 3. Turn engine ON. 4. Replace spark plug. 5. Service the carburetor.
Engine stops suddenly or stops when the engine rpm is increased	<ol style="list-style-type: none"> 1. See above 2. Main jet of the carburetor clogged with dirt. 3. Air filter element dirty. 4. Spark plug cap is loose 	<ol style="list-style-type: none"> 1. See above. 2. Take out main jet of the carburetor and clean with an air gun. 3. Clean the element. 4. Tightly fit cap to the plug.
Engine runs but unit does not produce impact	<ol style="list-style-type: none"> 1. Lack of engine power. 2. Clutch is slipping. 3. Power transmission gears are damaged. 	<ol style="list-style-type: none"> 1. See above 2. Dismantle clutch assembly, clean shoe and drum with proper solvent. Replace clutch shoe if necessary. 3. Contact dealer.

Technical Data

MODEL	RAM60B	RAM70C
DIMENSION (LxWxH) - mm (in)	740x360x1,030 (29.1x14.2x40.5)	740x360x1,030 (29.1x14.2x40.5)
OPERATING WEIGHT - KG	68	78
SHOE SIZE (LxW) - mm (in)	333x220 (13.4x10.8)	333x280 (13.4x10.8)
STROKE - mm (in)	65 (2.5)	70 (2.8)
IMPACT FORCE - KG (lb)	1,390 (3061)	1,600 (3524)
BLOWS PER MINUTE (bpm)	650 -700	650 -700
COMPACTION DEPTH (DEPENDING ON SOIL) - cm (in)	61 (24)	61 (24)
TRAVEL SPEED - m/min (ft/m)	9-12 (29.5-39.4)	9-12 (29.5-39.4)
COMPACTED AREA - m ² /h (ft ² /h)	235 (2529)	300 (3,229)
FUEL TANK CAPACITY- Ltr (gal)	3.8 (1)	3.8 (1)
ENGINE	ROBIN ER12/HONDA GX100	ROBIN ER12/HONDA GX100
ENGINE TYPE	Air-cooled single-cylinder 4-stroke Gasoline Engine	Air-cooled single-cylinder 4-stroke Gasoline Engine
POWER OUTPUT - hp (Kw)/3600RPM	3.5 (2.6) / 2.8(2.1)	3.5 (2.6) / 2.8(2.1)

Warranty

Your new rammer is warranted to the original purchaser for a period of one-year (12 months) from the original date of purchase.

The HOPPT warranty covers defects in design, materials and workmanship.

The following are not covered under the HOPPT warranty:

1. Damage caused by abuse, misuse, dropping or other similar damage caused by or as a result of failure to follow assembly, operation or user maintenance instructions.
2. Alterations, additions or repairs carried out by persons other than recognised agents.
3. Transportation or shipment costs to and from recognised agents, for repair or assessment against a warranty claim, on any machine.
4. Materials and/or labour costs to renew, repair or replace components due to fair wear and tear.
5. The engine, air filter and the engine spark plug.

HOPPT or their recognised agents, directors, employees or insurers will not be held liable for consequential or other damages, losses or expenses in connection with or by reason of or the inability to use the machine for any purpose.

Warranty Claims

All warranty claims should firstly be directed to HOPPT, either by telephone, by fax, by email, or in writing.

For warranty claims:

Uni-corp Singapore on +65 6756 7688

Notes



Uni-corp (Singapore) PTE Ltd

20 Ang Mo Kio Industrial Park 2A,
#03-02/03 AMK Techlink Singapore 567761

 +65 6756 7688

 +65 6756 7088

 sales@uni-corp.com

 www.uni-corp.com

